

Installation Guide - Falcon



Please read these instructions carefully before commencing installation and retain for future reference. If in doubt, we advise that you consult a qualified electrician to install the product. These products must not be modified, if modification is made or product is not installed with these installation instructions it will invalidate the warranty and may render the product unsafe.

Warning

1. For indoor and outdoor use .
2. If cable is defective, do not use or exchange the cable.
3. The light source of this luminaire is not replaceable; when the light source reaches its end of life the whole luminaire will need to be replaced.
4. We do recommend that a qualified electrician should be used to install the product.
5. Install in accordance with IEE Wiring regulations and current Building Regulations.
6. This light fitting should be connected to a fused circuit
7. If replacing an existing fitting, make a careful note of the connections.
8. Waste electrical products should not be disposed of with household waste. Please recycle where facilities exist. Check with your local authority for recycling advice.

Important safety Notes

1. Switch off the electricity at the mains before commencing installation and remove the appropriate circuit fuse to avoid accidental switching on of the mains supply.
2. Make sure all connections are tight with no loose strands.
3. Ensure fire regulations are not breached when fitting your lights.

Installation - Surface

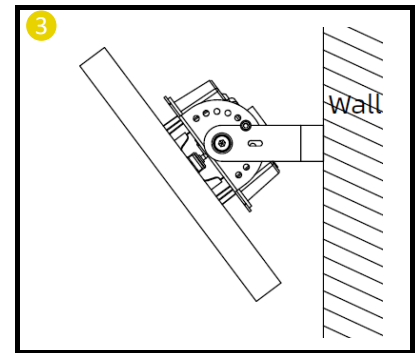
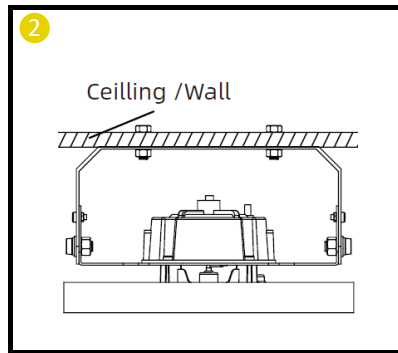
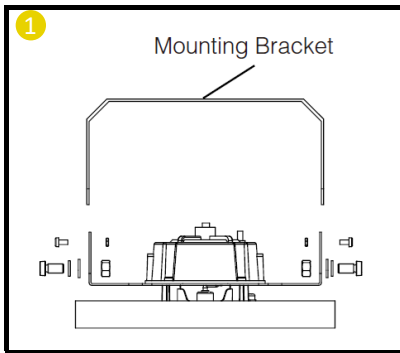

Installation—Suspended

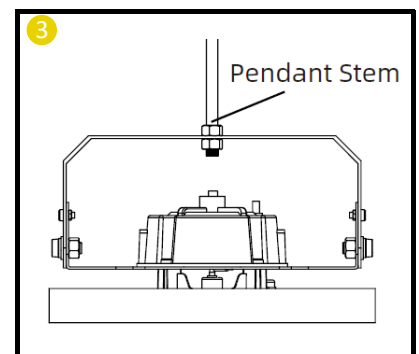
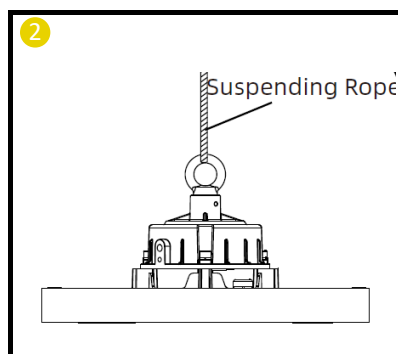
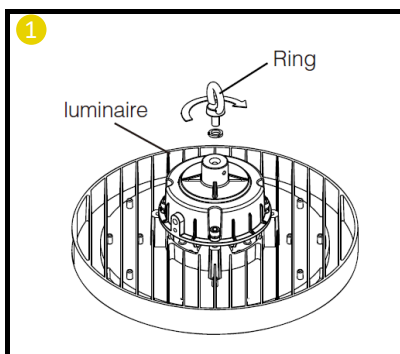

Wiring

Standard

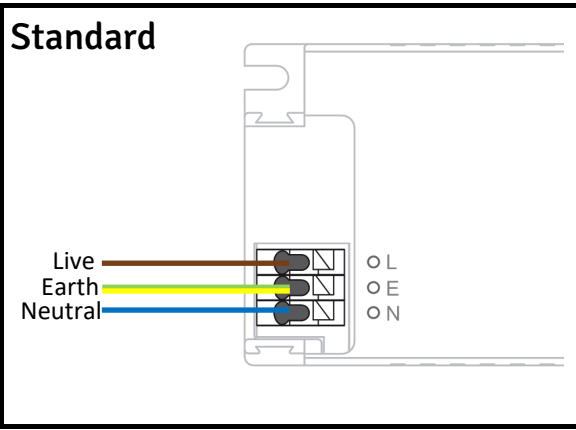

DALI (-DA)

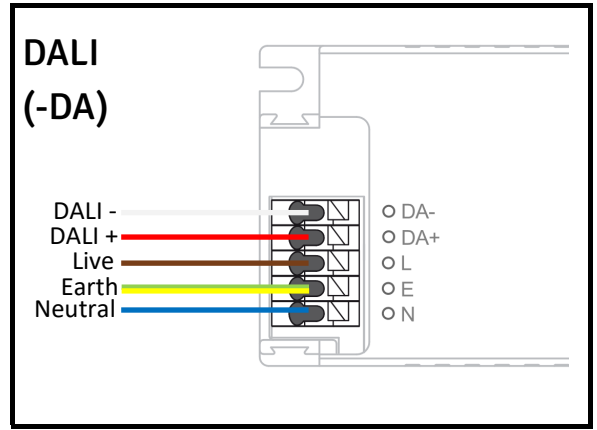

Standard EM (-E1)

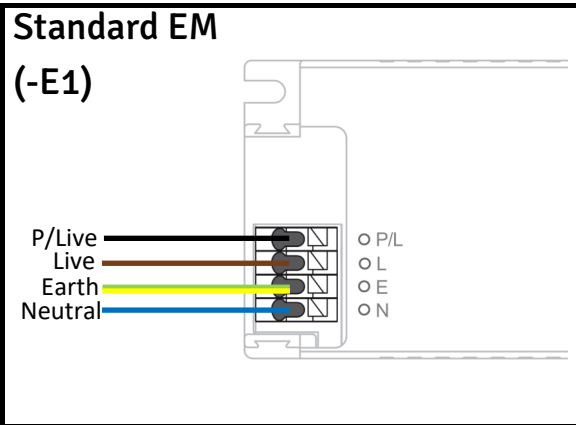

DALI EM (-E3)

